



MEMBERS  
HANDBOOK  
**2022**

## APPENDIX 3

### ELECTRIC CARS

#### A GENERAL

##### 1. RACETRACK SPECIFICATIONS for electric classes

- 1.1.1 For EFRA-sanctioned events, where non-permanent tracks are used, the track plans have to be submitted to the Section Chairman for approval.
- 1.1.2 Track-design must include both right and left-hand turns and one or more straights.
- 1.1.3 Minimum track length: 120 meters.
- 1.1.4 Outside barriers must provide a positive means of stopping a car that misses a corner or runs out of control.
- 1.1.5 Track marking equipment must be such a shape and size to prevent the entrapment of a car or the drivers view becoming obscured. 'Horizontally laid triangular column' shaped barriers and 'Bot dots' are not to be used.
- 1.1.6 Farthest point of the track must not be more than 50 meters away from driver's rostrum.
- 1.1.7 Time-keeping: preferable on a slow part of the track to enable accurate counting.
- 1.1.8 Marshall positions based on car numbers must be equally spread around the track. It should be clear which part of the track the specified position is responsible for.
- 1.1.9 A 220-volt electrical supply must be available at EC meetings with one outlet for every four drivers in close proximity to their pitting area. All safety precautions must be observed.
- 1.1.10 For the EFRA staggered start system one start line must be marked across the track, preferably close to the time-keeping's pick-up loop position (otherwise two).
- 1.1.11 All finals will use a "F1" type grid start with a minimum of 2/3 meter alternating intervals (Sections to determine) with two rows of cars. Cars must be placed forward facing to their marker-line or startbox.
- 1.1.12 Wherever possible the start line(s) must be accessible without crossing any other part of the track.
- 1.1.13 The start line will be white or yellow coloured, have a minimum width of 5cm and shall cover the total width of the track and will also be marked on the barriers. There shall be marked boxes for the final F1 grid.
- 1.1.14 Top Qualifying driver may choose his starting position on the grid either left or right, this then to be the configuration for all remaining finals.
- 1.1.15 Marshall intervention must be minimised by using smooth obstacles such as dots or cones, of appropriated heights.
- 1.2. Specific track requirements for 1/12 & 1/10 Touring class tracks
- 1.2.1 Indoor track surface must be needle carpet with smooth joints properly attached to the floor.
- 1.2.2 For onroad racing, only smooth surfaces will be allowed.
- 1.2.3 Indoor Limits: minimum track width 2 meters between the marking lines. At the start line the track must be at least 3 meters in width as far as the first turn. Marking lines must be either white or yellow, minimum width of 2.5 cm, and must be at least 20 cm away from the edge of the racing surface or track barrier.
- 1.2.4 The track surface for 1:10 Electric Saloon Cars can be both asphalt or needle carpet.
- 1.2.5 The track surface for 1/12th electric sports cars must be indoors on needle carpet.
- 1.3 Specific track requirements for 1/10 Off Road class tracks
- 1.3.1 Width: 3 metres minimum.
- 1.3.2 The spirit of scaled down off Road racing must be adhered to. (Modified On-Road tracks are not considered suitable).

- 1.3.3 If two Classes (2WD & 4WD) are to be held on the same track, it is preferred that the track should be significantly different for the two Classes. Reverse operation is acceptable. If tracks contain permanent jumps/features that cannot be easily changed or used in the reverse direction, then it is permissible to use the same track layout for both Classes (2WD & 4WD), subject to agreement with the Section Chairman at least two (2) months prior to the event.
- 1.3.4 Maximum track length: 250 meters.
- 1.4 Requirements for time-keeping equipment
- 1.4.1 The main timing PC must automatically announce the following in clear English: 2 minutes to the start of the race 30 Seconds to the start of the race (& start order for staggered starts at this point) 10 second countdown and start 'Sound' for line starts (i.e. finals) 10 second countdown and call the cars off the line in case of staggered starts Time calls and race order every 2 minutes Cars finished & race over
- 2. MOTORS FOR ELECTRIC SCALE CARS:  
FROM 2018, all Rules concerning:-  
Technical Specifications and Homologation Procedures for Brushless Motors 05 Size, have been moved to NEW APPENDIX 4.**
- Each Electric Section, for all EC and GP events will clearly state which class of motors are to be used.
- From May 2016, only motors included on the EFRA Homologation Lists are allowed at EC and GP events in the Electric Classes.
- 3. BATTERIES  
FROM 2018, all Rules concerning:-  
Technical Specifications, Race Procedures, Homologation Procedures, for Lithium Batteries have been moved to NEW APPENDIX 4.**
- Each Electric Section will define the number of cells and nominal rated voltage.
- 3.1 1/12th. Cars will be driven by lithium based (LiPo/LiFe) batteries with a nominal voltage of no more than 3.8 volt (effective from 01.03.17). Receiver batteries are allowed.
- 3.2 1/10 Touring scale, TC, FWD and Formula 1 cars will be driven by a lithium based (LiPo/LiFe) battery with a nominal voltage of no more than 7.6v (LiPo)/ 6.6v (LiFe). Receiver batteries are not allowed.
- 3.3 1/10 Off-Road Scale cars will be driven by lithium based (LiPo/LiFe) batteries with a nominal voltage of no more than 7.6v (LiPo)/ 6.6v (LiFe). Receiver batteries are not allowed.
- 3.4 LiPo/LiFe drive batteries must be in a 'Lipo sack' at all times when being charged or discharged. This applies to any discharging procedures except during a race or when using organiser supplied resistors. Anybody not doing this, will be penalized at the event.
- LiPo sack is defined as a receptacle designed for the purpose of charging LiPo/LiFe batteries and of a suitable construction as to contain a LiPo/LiFe fire.
- 3.5 **The maximum charging cut-off will remain at 4.20v per cell.**
- 4. ELECTRONIC DRIVING AIDS**
- 4.1 The radio control receiver in the car may operate steering and motor management. A separate battery supply for the powering of the timing equipment is allowed. Using the receiver to capture electrical signals from sensors carried in the car is prohibited, be it wireless or not.
- 4.2 Automated steering, gyroscopes to control car movement, traction control, active suspension are not allowed
- 4.3 The speed controller may have a device to limit the current/voltage passed

from the batteries to the drive motor (e.g. timed delay, current limiter, keyboard programs) as well as a passive data recording device but setting or programming of these devices must only be possible whilst the car is stationary.

- 4.3.1 Events that are designated for using 'Spec. Class Brushless motors' will only allow a Speedo that has a 'zero timing profile', that does not alter the preset mechanical timing of the motor in any way and disables any advanced motor control; functions (ie. Boost, Cheat mode, Turbo etc.). This profile is known as ' Boost 0'. The commutation sequence is limited to "6-step" type and commutation of the Speed control must follow the motors hall sensor signals 1:1. Therefore no change of timing (either advance or retard) is allowed at any RPM." When the "Boost 0" profile is activated, it will be identified by a blinking LED while the ESC is armed and in neutral position.
- 4.4 No other signals than these for the official lap counting transponder may be sent from the car.
- 4.5 Any competitor found in contravention of the spirit or fact will be disqualified from the meeting. The race organiser has the right to inspect any car, its components and transmitter at any time during the race event.

## **5. DRIVER PROCEDURE**

- 5.1 Before your heat, and if hand out equipment is available and needed, collect the auto timing equipment from dispatch and fix it to the car.
- 5.1.1 When hand out auto-timing equipment is used, it is the driver's responsibility to fit it appropriately to the car and to remove it after timed heat if required.
- 5.2 When a personal transponder is used the driver is entirely responsible for the efficient functioning of the device.
- 5.3 As soon as race control allows, collect your transmitter, switch on and drive car to the start line.
- 5.4 When your heat has finished. Return transmitter, retrieve your car, switch off and bring it to scrutinizing with the handout auto timing equipment if required.
- 5.5 Marshal the heat following your own at the numbered position corresponding to your car number.
- 5.6 Collect your car from scrutinizing after marshalling.
- 5.7 The race director may demand the drivers to stand on the indicated positions on the rostrum.
- 5.8 The race director has absolute authority at the meeting but refer to your team manager if you encounter problems.
- 5.9 It is not allowed to enter/access the rostrum until the previous race is declared over by race control. It is not allowed to leave the rostrum before the race is declared over by race control. Penalties can be applied to competitors that do not adhere to this procedure.
- 5.10 At 1/12Track, 1/10Track and 1/10 Off-Road electric events, no radio communication or any other form of communication deemed to be an advantage between the driver and pit crew is allowed during any Heat or Final. There will be no form of 'coaching' to drivers during any Heat or Final.

## **7. EUROPEAN CHAMPIONSHIPS**

- 7.1 European Championships will take place every year there is no World Championship in the concerned class held within Europe. However the general meeting can decide otherwise if deemed to be in the interest of the sport.
- 7.1.1 European Championships are held in the following classes:  
1/10 Off-Road Modified, 2WD & 4WD as separate Classes.  
1/12 Modified, using no less than 6.5 turn modified brushless and blinky.  
1/12 Spec using 13.5 T Spec. brushless and blinky.

1/10 Touring Cars Modified & 1/10 Touring Cars using 13.5T Spec. Brushless  
1/10 Formula One using 21.5T Spec. Brushless.

1/10 Touring Car FWD using 21.5T Spec. Brushless and Blinky

Starting May 2016, only motors included on the EFRA Homologation Lists are allowed at EC and GP events in the above Classes.

## 7.2 ALLOCATIONS

7.2.1 The country allocations for the EFRA European Championships will be established by the section meeting and published in the minutes.

7.2.2 Allocation and re-allocations are according to the general rules.

7.2.3 If available all countries receive re-allocated places in order of the allocation list, unless stated otherwise in this list. Any Federation requiring to be considered for re-allocations should put their request in writing to the Section Chairman no later than 21st January.

7.2.4 100 entrants for 1/12 and 130 for 1/10 Off-Road (One may consider up to 150 participants if timetable and facilities i.e. driver tables etc, permit) are to be accepted for European Championships and GP's. For 1/10 Touring Car Modified & 1/10 Touring Car 13.5T Spec. Brushless up to 150 entrants have to be accepted for European Championships and GPs. The allocations 1/10 Touring Car modified will be decided at the section meeting first. When all allocations are confirmed the remainder of unfilled entries made available as open entry for the 1/10 Touring spec class.

7.2.5 For EC's any countries allotment is in no case to be higher than 33% of the total number of allocated entries ("No-Show's" and last minute cancelling drivers are not to be considered).

7.2.6 a) The preceding year's European Champion will automatically be allocated a place from the EFRA allocation for the World Championships.

b) The reigning World Champion, if European, will automatically be allocated a place in the following two European Championships.

c) The reigning European Champion will automatically be allocated a place in the following European Championship

7.2.7. Drivers that finished in the Top 10 at a 1/10 Touring Car Modified European Championship (indoor or outdoor) in the last two championships held are not allowed to participate at the 1/10 Touring Cars 13.5T Spec. Brushless and the TC FWD 21.5T Spec. Brushless Blinky European Championship. At the 1/10 Touring Car modified & 1/10 Touring Car 13.5T Spec. Brushless European Championships drivers are only allowed to enter one of the two classes. All other drivers may compete in either 1/10 Touring Car Modified and TC FWD or 1/10 Touring Car 13.5T Spec. Brushless and TC FWD.

## 8. TIME TABLES:

8.1 The Race Organiser must schedule all events for each day to be completed and the track closed by 18.30 hours. The pit area must be available for 1:30 hour after the last race. For 1/12th scale events it is recommend to complete each day by 19.30. It is recommended to end the last day early enough to allow participants to start their return journey.

8.1.1. 1/12th EUROPEAN CHAMPIONSHIP:

Friday: 1-2 Rounds of un-timed practice (organizers discretion) 2 Rounds of timed practice Opening Ceremony (a limited heat re-seed, based on average lap times of timed practice 1 & 2, will be carried out while the opening ceremony is taking place) 1-2 Rounds of timed practice in new heat format 1 Round of qualifying (In heats used for the last 2 rounds of controlled practice). Total of 5 or 6 rounds of qualifying to

be run depending on amount of participants). 6 rounds of qualifying recommended to be run.

Saturday: 1 Round of controlled practice in heats (warm-up) 4-8min recommended.

5-6 Rounds of Qualifying (depending if one round was run on Friday already)

Sunday: 1 Controlled practice for A-final  
3 rounds (legs) of all finals

8.1.2. 1/10th Touring, 1/10th Formula One & 1/10th FWD EUROPEAN CHAMPIONSHIP:  
DAY 1:\* 09:00 Registration, Open and a minimum 2 timed practice, 2 rounds of controlled Practice and 1 Qualifying Round

DAY 2:\* 09:00 1 timed practice (minimum) and 4 Qualifying Rounds

DAY 3:\* 09:00 1 Practice Final (minimum) and 3 finals for all. There will be a minimum of 10 min between start of round.

Based on the numbers of participants, this timetable can be changed by the organiser with agreement by the section chairman.

\*To be agreed at AGM.

8.1.3. 1/10 Elec. Off-Road EUROPEAN CHAMPIONSHIP:

MONDAY: Free practice 2WD, Registration and Technical Inspection

TUESDAY: Two Rounds of Controlled Practice and Qualifying Rounds 1-3  
WEDNESDAY: Schedule permitting, one hour of unofficial practice in Heat Order of Round 4

Qualifying Rounds 4-5, Finals and Prize Ceremony

THURSDAY: Free practice 4WD, Registration and Technical Inspection

FRIDAY: Two Rounds of Controlled Practice and Qualifying Rounds 1-3

SATURDAY: Schedule permitting, one hour of unofficial practice in Heat Order of Round 4.

Qualifying Rounds 4-5, Finals and Prize Ceremony

The Race Organiser can change the above timetable providing he does so well in advance. ALL changes to the Schedule or alterations to times of any Heats/ Finals must be clearly identified to all Team managers and Officials in written form, at least one hour before such changes take place, if any procedures are being brought forward.

No request for a delayed start in Qualifying will be granted. In "A" Finals, a competitor may request a delayed start of up to a maximum of eight (8) minutes for the repair of breakages only, subject to the Race Director agreement. The competitor(s) involved will then start from the back of the grid. This delay will only be granted once for any "A" Final.

8.2 TIMETABLE FOR GRAND PRIX MEETINGS

8.2.1 The timetable for Grand Prix will be left to the discretion of the Organisers taking into consideration the number of competitors in each class. Organiser can determine the Timetable for all racing

## 9. RACING FORMAT EFRA EUROPEAN CHAMPIONSHIPS AND GRAND PRIX

### 9.1 PRACTICE

9.1.1 Free practice for E.C. events must be allowed as stated in the concerned timetable. No practice or racing is allowed on the track for 7 days preceding this (see also General rule 8.1.).

9.1.2 For all EC's: 2 series of organised practice with cars grouped in heats will be held with at least one using the official time-keeping system.

9.1.3 During controlled practice the driver must be present and his transmitter switched on for checking radio interference.



9.1.4. Practice heats at 1/10 Touring Car Modified, 1/10 Touring Car 13.5T Spec. Brushless, 1/10 F1 European Championships & 1/10 TC FWD European Championships must not be longer than 5 minutes. In between two heats there can be a break of up to 3 minutes maximum.

## 9.2 START PROCEDURE

9.2.1 There will be a minimum of seven (7) minutes between the starts of heats, (10) ten for 1/12th.

9.2.2 Qualifying heats: the delayed start procedure (Staggered Start) will be used and a verbal start signal, mentioning the car number, will be given for each car. Cars must start when directed by the Start Official. Cars not starting when directed may start after the last car has crossed the lap counting loop

9.2.3 Finals: After the 30 seconds signal, cars not on their start grid must be placed at the rear of the grid. An audible signal generated by the timing equipment will be given after the "ten seconds" in a random delay of between 1 and 5 seconds.

9.2.4 Jump-starts (after 10-second signal) - front wheels crossing start line or their marked startbox - 10-second penalty. Front wheels crossing the line or box by one-meter: 1 lap penalty. Jump-starts are no reason for a re-start.

## 9.3 RESTART PROCEDURE

9.3.1 The Race Director or the Assistant Director, in absence of the race director, may order a restart.

9.3.2 In the event of an aborted start procedure; race must restart at least from the "30 seconds" before the start" announcement.

9.3.3 If the race is stopped before the first car has completed a full lap of the track then the race will be immediately re-started after the reason for the stoppage has been cleared. If the race is stopped after the first car has completed a full lap then the race will be re-run at a convenient time allowing for the recharging of batteries.

## 9.4 QUALIFYING

9.4.1 1/12 Track:- The Qualifying Heats and Finals will be 8 minutes and the last lap plus the time to complete this last lap up to a max of 40 seconds. The Round by Round point system will be used. This system awards points to all drivers based on their finish position against all others for each round individually.

All cars must be cleared by technical inspection before any result can be used for seeding.

When the 'Round by Round' qualifying method is used, the number of Qualifying Rounds to count are as follows :-

Number of Rounds completed	1	2	3	4	5	6
To count - 1/12	Void	1	2	2	2	3

If less than two Rounds are completed the event is declared null and void.

Any Qualifying Round has to be completed for any Heats in that Round to be awarded points that count. Fastest competitor (based on laps & time) in each Round will score zero (0) points, second place 2 points, third place 3 points, fourth place 4 points and so on. If two (or more) competitors achieve an equal time in any Round they will be awarded equal points. The next competitor not included in the tie will be awarded points corresponding to his position in the particular Round. (NOTE: drivers not recording a time or having a time disqualified in any Round score points for last place in that Round).

Overall Qualifying positions are decided by each drivers 'best' (lowest) points being added together, based on the number of Rounds to count as shown in above table. In the event of a tied position the driver with the single highest finishing position in either of the best Rounds that counted will be awarded the

tie (eg. 1+3 = 4 beats 2+2 = 4). In the event of a continuing tie then the laps and times from the best points Round will be compared. The driver with the fastest laps and time will be awarded the tie. In the case of a continuing tie, then the times from the second best scores will be compared.

Only counting Rounds will be used to decide Qualifying positions (or ties), all other Qualifying Round scores and times will be discarded.

If the intended maximum number of Rounds cannot be completed, due to weather or unforeseen circumstances, the number of Rounds to count will follow the same format as the table above.

9.4.2 1/10 Off-Road:- The Qualifying Heats and Finals will be 5 minutes and the last lap plus the time to complete this last lap up to a max of 40 seconds. The Round by Round point system will be used. This system awards points to all drivers based on their finish position against all others for each round individually.

When the 'Round by Round' qualifying method is used, the number of Qualifying Rounds to count are as follows :-

Number of Rounds completed	1	2	3	4	5	6
To count - 1/10 Off-Road	Void	1	2	2	2	3

If less than two Rounds are completed the event is declared null and void.

Any Qualifying Round has to be completed for any Heats in that Round to be awarded points that count.

Fastest competitor (based on laps & time) in each Round will score zero (0) points, second place 2 points, third place 3 points, fourth place 4 points and so on. If two (or more) competitors achieve an equal time in any Round they will be awarded equal points. The next competitor not included in the tie will be awarded points corresponding to his position in the particular Round. (NOTE: drivers not recording a time or having a time disqualified in any Round score points for last place in that Round)

Overall Qualifying positions are decided by each drivers 'best' (lowest) points being added together, based on the number of Rounds to count as shown in above table. In the event of a tied position the driver with the single highest finishing position in either of the best Rounds that counted will be awarded the tie (eg. 1+3 = 4 beats 2+2 = 4). In the event of a continuing tie then the laps and times from the best points Round will be compared. The driver with the fastest laps and time will be awarded the tie. In the case of a continuing tie, then the times from the second best scores will be compared.

Only counting Rounds will be used to decide Qualifying positions (or ties), all other Qualifying Round scores and times will be discarded.

If the intended maximum number of Rounds cannot be completed, due to weather or unforeseen circumstances, the number of Rounds to count will follow the same format as the table above.

9.4.3 1/10 Touring Cars, Formula 1 and TC FWD :- The Qualifying Heats and Finals will be 5 minutes and the last lap plus the time to complete this last lap up to a max of 40 seconds.

All cars must be cleared by technical inspection before any result can be used for seeding.

At the start of the event at Team Managers Meeting (on Friday morning) it will be decided if the Qualification Rounds will be declared dry or wet based on the weather conditions.

9.4.3a If Qualifying Rounds are declared to be dry, then the Round by Round point system will be used. The number of Rounds to count are as follows:



Number of Rounds completed	1	2	3	4	5	6
To count - 1/10 Touring Car	Void	1	2	2	2	3

If less than two Rounds are completed the event is declared null and void.

Any Qualifying Round has to be completed for any Heats in that Round to be awarded points that count.

Fastest competitor (based on laps & time) in each Round will score zero (0) points, second place 2 points, third place 3 points, fourth place 4 points and so on. If two (or more) competitors achieve an equal time in any Round they will be awarded equal points. The next competitor not included in the tie will be awarded points corresponding to his position in the particular Round. (NOTE: drivers not record. ing a time or having a time disqualified in any Round score points for last place in that Round)

Overall Qualifying positions are decided by each drivers 'best' (lowest) points being added together, based on the number of Rounds to count as shown in above table. In the event of a tied position the driver with the single highest finishing position in either of the best Rounds that counted will be awarded the tie (eg. 1+3 = 4 beats 2+2 = 4). In the event of a continuing tie then the laps and times from the best points Round will be compared.

The driver with the fastest laps and time will be awarded the tie. In the case of a continuing tie, then the times from the second best scores will be compared. Only counting Rounds will be used to decide Qualifying positions (or ties), all other Qualifying Round scores and times will be discarded.

If the intended maximum number of Rounds cannot be completed, due to weather or unforeseen circumstances, the number of Rounds to count will follow the same format as the table above.

9.4.3b If Qualifying Rounds are declared to be wet, then each competitors 2 fastest times will be added together to decide the Final Qualifying order.

Any Qualifying Round has to be completed for the times of any Heats in that Round to be used.

If it is impossible to complete all qualifying heats under the same weather conditions, (wet, semi wet or total dry) the following rule will become effective:- Before the start of every heat the race director has to announce if it will be a dry heat or a wet heat.

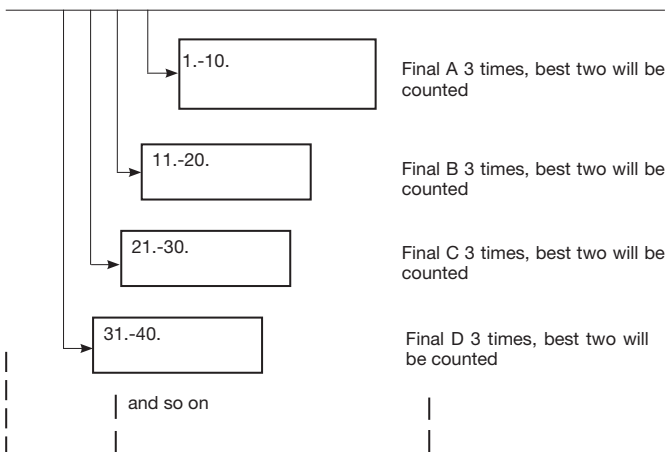

The Race Director is also allowed to declare during a Heat, that the Heat is “now running under wet conditions”. After a Heat has been completed, the Race Director can declare that the specific Heat was run under wet conditions if he/she decides the average lap times during the heat (or part if the Heat) were more than 20% slower.

If every Heat (Group) has at least one dry race in the Qualifying Rounds completed, then the 2 fastest times from all completed Rounds will be used. If any Heat (Group) does not have a dry race, then only the 2 fastest times from the wet Rounds will be used to decide the Final Qualifying order.

- 9.4.4 If the Round by Round system is used:- Then any driver incurring a penalty which results in his time and therefore points in any Round being disallowed, then all drivers below the disallowed position will move up one place. (In the event the penalized driver is a tie on obtained points the one with the best time will be lost).
- 9.4.5 The qualifying heats will be a maximum of 10 drivers and where possible equal number of drivers in each.
- 9.4.6 Cars will start in one line across the track in staggered start mode for the qualifying heats.
- 9.4.7 During the first round of qualifying, heat-starting order will be determined by the driver's performance in controlled practice based on his 2/3 best consecutive laps during the last two Rounds of controlled practice (Start order for CP2 is determined by the finishing time of CP1). During further rounds, heat-starting order will be by the fastest time of drivers in the heat from any previous rounds results used for qualifying positions. This will apply whether the Fastest Time Qualifying System or Round by Round System is used.
- 9.4.8 In order to give drivers an equal chance during qualification, organiser may reseed these drivers that are obviously way above or under the average in their group into a more suitable heat whenever possible. If lap times are used to reseed, then all cars must have passed technical inspection. Drivers must use their own car.
- 9.4.9 Off road heats will be run in the following sequence for the 5 qualifying rounds:  
Round 1: 1, 2, 3, 4, 5, 6, 7, 8, 9, 10, 11, 12, 13  
Round 2: 4, 5, 6, 7, 8, 9, 10, 11, 12, 13, 1, 2, 3  
Round 3: 7, 8, 9, 10, 11, 12, 13, 1, 2, 3, 4, 5, 6  
Round 4: 10, 11, 12, 13, 1, 2, 3, 4, 5, 6, 7, 8, 9  
Round 5: 13, 12, 11, 10, 9, 8, 7, 6, 5, 4, 3, 2, 1.  
On road heats will always be run from 1 to 15.
- 9.4.10 If the number of Heats differs from the format detailed in 9.4.9, or if the event is planned with more/less Rounds, a sequence following this general theme has to be used.
- 9.4.11 The qualifying results will determine the composition of all finals with the top 10 proceeding to the “A” final and so on down.
- 9.4.12 Off road: One round of controlled practice using the official time keeping will be organized for the A finalists. On road: A controlled practice will be applicable to all finals.
- 9.4.13 Qualifying results will be published after each round

## **10 FINALS**

- 10.1 There will be 10 drivers in all finals where possible. Finals will be organized for all competitors.
- 10.1.1 If the lowest Sub-Final has less than 4 drivers, they will be mixed as equally as possible in the next Sub-Final, respecting their qualifying position for their start order
- 10.2 The winner determined from the combined A finals will be the champion. If

- the A finals cannot be completed, the awards will be made based on the final Qualifying positions.
- 10.3 Off Road: The "A" final will be run in three legs. All other Finals will be one leg. Each race of the main "A" final will be considered a separate race. The finals will be run from slow to fast with the 3 legs of the "A" final in between.  
On Road: All finals will be run in 3 legs from slow to fast.
- 10.4 If three leg finals are run, then the best 2 out of 3 to count.
- 10.5 The winner of a final gets 1 point; the second gets 2 points and so on up to 10 points for the 10th driver. In the event of a tie regarding time in a Final, the points will be equally awarded to each driver and the next driver not tying will be two points more.
- 10.6 In the event of a tied position the driver with the single highest finishing position in either of the best 2 finals that counted will be awarded the tie. In the event of a continuing tie then the laps and times from the highest finishing position will be compared. The driver with the fastest laps and time total will be awarded the tie. In the case of a continuing tie, then the times from the second best position will be compared.  
When some drivers of a final do not run a final, they will be awarded the remaining points in the order of their car numbers.
- 10.7 Cars which do not pass the start/finish line after the prescribed race time, will be classified according to the number of laps recorded. The "A" finalist with the lowest number of points will be the European Champion or the winner of the grand prix.
- 10.8 All final results will be published at least 10 minutes before prize giving.
- 10.9 There will be awards at least for all "A" finalists, and the winners of any other final. If no round of Final(s) are completed the results of the event are taken on qualifying positions.
- 11. TECHNICAL INSPECTION**
- 11.1 All cars may be called for technical inspection at any time but must always be presented for scrutinizing. (11.4 remains in force).
- 11.2 Failure to meet the technical rules will result in loss of the concerned heat result.
- 11.3 Non-compliance obviously resulting from race incidents will not be accounted for at scrutinising
- 11.4 After "A" finals the cars must be collected and impounded by organiser's staff ("parc fermé").
- 11.5 The motors of the top 3 finishers may be dismantled in order to check their conformity with the rules.
- 11.6 It is allowed to change the chassis of the car, providing the replacement is of the same design, specifications and material as the original item that was registered prior to the start of racing. The new chassis has to be registered and presented to the authority.
- 12. GENERAL REQUIREMENTS FOR COMPETITION CARS IN ELECTRIC CLASSES**
- 12.1 Cars must be realistic and when initially entered in the meeting have neatly finished and complete body shells.
- 12.2 Open cockpit cars must have a realistic driver figure fitted in an appropriate position at all times when racing. This consists of at least a driver's head/helmet and should be painted in a realistic appearance, colour and garb.
- 12.3 The body and chassis must be securely joined at all times when the car is on the track. Driving on the track without body is not allowed at any time.
- 12.4 All cars shall have identifying numbers in at least three positions, right, left and on front of the car. The numbers must be put on the body shell so the numbers are easily seen by the referee or race director.

- 12.5 No car shall be constructed so as to be dangerous or damage the track surface or other competitor's cars.
- 12.6 The cars must allow fitting a time keeping transponder in a suitable position with the correct orientation.
- 12.7 Any type of speed controller, not causing interference's of any kind to lap count, computers, transmitters etc., may be used, but it must be contained within the car and not protrude through the body shell.
- 12.8 All cars must have a transparent windscreen. Open or painted windscreens are not allowed except for models of prototypes that did not have windscreens.
- 12.9 Side or rear windows must be clear. The driver may have his name on the side window in the same scale as the car.
- 12.10 Openings in the body must be appropriate to the full size prototype (Scoops, vents etc.).
- 12.11 Wheel arches must be cut out if the prototype ran that way.
- 12.12 Tyres must be black except sidewall detailing.
- 12.13 Openings for wing mount or antenna shall provide no more than 10 mm clearance.
- 12.14 Definition of a wing: A wing is an additional item attached to the car.
- 12.15 Definition of a Spoiler: A spoiler is that which is moulded in the body.
- 12.16 Spoiler and side dam dimensions include that which is moulded into the body.
- 12.17 Bumpers are not required. If fitted, bumpers must be constructed so as to minimise injury that may result from being hit by a car. The overall width may not exceed the overall width of the front of the car, including wheels.
- 12.18 Wire bumpers shall be made of wire between 2.5 mm and 4 mm in diameter. Bumpers made from sheet type material shall be between 2.5 mm and 6.5 mm thick, with all exposed edges smooth and well rounded. Closed cell foam (i.e Pu-RIM) bumpers may be 2cm thick Rigid blade-like bumpers made of hard, non-resilient material such as metal, brittle plastic, plywood, masonite etc., are not allowed.
- 12.19 All weight minima are applicable to cars equipped with fixed personal transponder as well as for those using (hand-out) auto-powered transponders. The later are to match the minima including transponder (whatever the type).

## **B REQUIREMENTS FOR ELECTRIC ON ROAD CLASSES**

### **1. GENERALITIES**

- 1.1 On carpet tracks a minimum ground clearance of 3mm (excluding spur gear) for 1/12 and 5mm for 1/10 is mandatory at the start of each heat and final.
- 1.2 Up to a maximum of two chassis may be submitted to Technical inspection, either of these chassis may be used at any time during the event. The second chassis may be approved after the event has started.

### **2. BODIES:**

- 2.1 Any newly homologated bodies must have the part number moulded into the front windscreen. For 1/10 Formula One Spec class, no body homologation is required.
- 2.2 Body cannot be trimmed higher than lower body trim lines.
- 2.3 No portion of chassis, wheels and tyres, or equipment may extend beyond body except to the rear. (Exception -Formula car suspension chassis and abbreviated bodies with no engine cover).
- 2.4 No more than 1.5 mm of wheel outside diameter may be exposed on the outside of the wheel (i.e. not covered by the tyre). If wheel discs are used they should be secured by a screw or clip.

2.5 In all classes where possible, an 8th scale number must in addition be placed on the roof of the body (NASCAR style) for absolute best identification. Numbers on front windscreens must be avoided

2.6 The organizers will supply the numbers.

### 3. **ROLL-OVER MASTS:**

3.1 A rollover mast may be fitted. If so, it must have a blunt end for safety reasons, terminate in a closed loop at least 4.75 mm O.D. or a ball or button not less than 8 mm in diameter.

3.2 If a rollover mast and radio antenna is fitted, the antenna must be part of the mast along its length. Max. Height from ground 35 cm.

### 4. **BUMPERS**

4.1 All cars may run a rear bumper, which must be behind rear tyres.

4.2 If used, front bumpers must be flat; parallel to the ground in all directions.

### 5. **TYRE ADDITIVES / TRACTION IMPROVING TREATMENTS:**

5.1 All Tyre treatments, governed by health, nuisance and track damage considerations will be at the discretion of the organisers and EFRA. i.e. Normally only odourless tyre cleaners or traction additives will be allowed.

5.2 It is down to the organiser / section chairman to specify the additive to be used at an event.

(1/12 scale only) A list of legal additives will be maintained by the Section Chairman and published at least 1 month prior to each event. Only tyre additives on the published list may be used. New additives may be added during a season, subject to approval by the section chairman.

The use of tyre treatments is the user's responsibility. EFRA draw organiser's attention to the possible hazard created by large numbers of competitors using tyre treatments in a confined space. EFRA recommend that the competitor adheres to the methods of usage as stated by the supplier of the treatment.

5.4 At European Championships it is only allowed to use the tyre additive agreed by the section meeting at the EFRA AGM together with the race organiser (race organiser will make their recommendation).

5.5 It is recommended that the chemical components of these products must be harmless for people and environment. Liability at the use of tyre additives lies at the user and manufacturer.

### 6. **PARTICULAR TO 1/12th SPORTS CARS**

The ethos of this class is the preparation and piloting skills, while operating within tightly controlled rules, bring rewards rather than the technological advantage of any particular marque of car. The rules have been questioned relating to drive and suspension. We will assume that the following is true.

Rear suspension and drive. Single solid one-piece axle only. No independent suspension allowed. A differential may be used.

Anything other than this will be presented at the first meeting of the EC for the team Managers to consider if the deviation is within the spirit of the sport.

The 1/12th class is separated in two main classes: LMP and GT 17.5.

The rules outlined below may not necessarily cover every single aspect of car construction - drivers are required to follow the spirit and intention of these rules if any ambiguity is discovered.

**LMP class:** The LMP class is a representation of Prototype Sports cars as e.g. Le Mans Cars and is intended for experienced or professional drivers. The LMP class is divided in "Modified" and "SPEC 13.5" class.

**LMP 17.5 class:** The LMP class is a representation of current FIA GT Competition

cars with a more scale look. With a lower motorization than the “SPEC 13.5” class, the “LMP 17.5” class is intended for beginners and senior drivers. Due to a lot of commonalities to the LMP class the “LMP 17.5” class can be used as a starting base for an upgrade to LMP or a downgrade from LMP to ensure keeping racing costs reasonable.

On LMP 17.5 any 17.5 brushless Motor of the EFRA Homologation List for Brushless Spec Motors (17.5) can be used with any Speed controllers (ESC) using “0-Boost/Blinky” Mode “Speed Controllers” according approved Blinky ESC’s list. Drivers who finished in an A-Main final in LMP “Modified” or “SPEC 13.5” in the previous season at a World Championship, a European Championship or a National Championship are not allowed to start in the GT 17.5 class in the actual season.

6.1 BODIES:

6.1.1 LMP body shells must be submitted to the EFRA Body shell Homologation Officer for approval. A list of homologated bodies must be sent with the drivers package and to the organisers and be available on the EFRA website.

The following is the specification for approval of 1/12 Prototype Sports car body shells. They should be used by the Homologation officer to enable clear and consistent application of standards for future approvals,

Lower body cut line is to be used as the reference plane for all height dimensions.

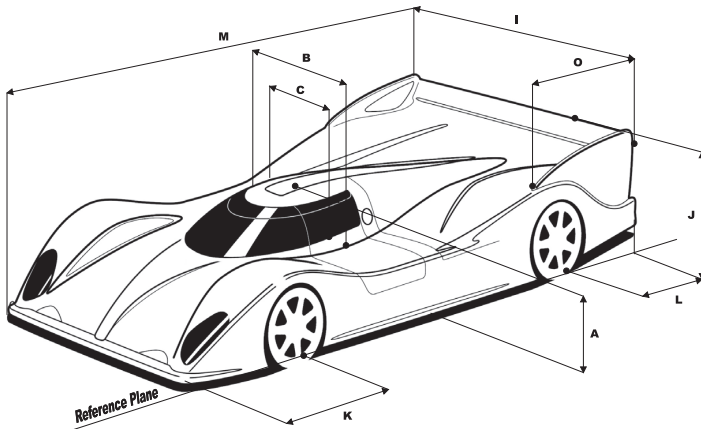

A	Min 55mm	I	168 to 176mm
B	Min 70mm	J	Max 65mm
C	Min 55mm	K	Max 70mm
D	Min 50mm	L	Max 70mm
E	Min 11mm	M	Max 340mm
F	Min 65mm	N	Min 50mm
G	Min 46mm	O	Max 110mm
H	Min 50mm	P	Max 72mm

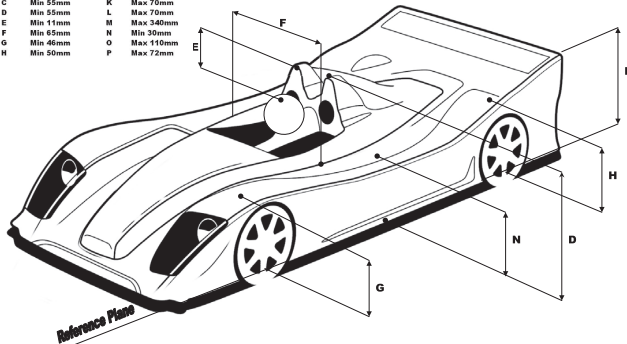

Minimum cockpit height – Closed cockpit – 55mm (Excluding any air scoops / air boxes) Minimum cockpit width – Closed cockpit – 70mm (Measured at the point it intersects with the side pod)

Minimum cockpit width - 55mm (measured at the lower window line)

Minimum Roll bar height – Open cockpit – 55mm

Maximum distance from Drivers helmet to top of roll bar – Open cockpit -11mm

Minimum cockpit width – Open cockpit – 65mm (Measured at the point it intersects with the side pod)

Minimum front wheel arch height – 46mm (Including vents) (measured at a point 15mm from edge of body)

Minimum rear wheel arch height – 50mm (measured at a point 10mm from edge of body)

Maximum overall width – 176mm

Minimum overall width – 168mm

Max. wing / spoiler height – 65mm

Max. front overhang (From centre of front wheel)– 70mm

Max. rear overhang (from centre of rear wheel) – 70mm

Max. length overall – 340mm

Minimum side pod height – 30mm

The side dam must blend fully (disappear) into the main body shape within 110mm of the rear edge of the body/side dam.

Max side dam height – 72mm

The body side forward of the side dam must have a radiused edge, no lips or upward extensions are acceptable

Bodies must be a reasonable representation of a full size LMES / ALMS / LMP / WSC prototype.

Open cockpit cars to have twin roll bars as current LMES / ALMS

Open cockpit cars must have a representative drivers helmet and cockpit opening

The name of the prototype must be used for the homologation process.

The name of the prototype does not have to be used for general sales and marketing.

Only fins or strakes that are present on the full size prototype will be allowed.

The body must not be cut above the lower cut line.

Cut-outs in the shell will be allowed only if clearly defined on the full size prototype.

Once Homologated there must be no changes to the design, trim lines, detail lines or any feature of the body. All changes will require resubmission for approval and an additional revision letter added to the part number- Example 15001A - Original - 15001B for a 2ndRev. Etc

The manufacturer's par number must be clearly marked on the shell alongside the windscreen area

All new homologation must meet the above criteria.

6.1.2 Wheel cut-outs may not be more than 15 mm larger than tyre radius (Exception -scale size and/or shape wheel cut-outs). Wheel wells must be cut out if those on the original car were cut out.

6.1.3 Only one wing is allowed on the car unless the actual car had a second wing. The second wing must be scale within 10% in size and location. The wing may be not closer than 6.5 mm to any part of the body other than the tail fins or side dams.

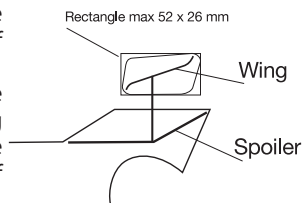



- 6.1.4 Maximum width: 172 mm, the wing profile must fit in a rectangle of 52mm (height) x 26 mm.  
Spoilers: Max. Spoiler height: 25 mm, max length 35 mm.  
These dimensions include the moulded in portions of the body, the use of a gurney flap to extend the wing length is acceptable.
- 6.1.5 Wing and Spoiler GT class: Only one wing is allowed on the car, maximum dimensions to be, width 165 mm, chord 50mm, unless the original car had more than one wing. The second wing must be to scale within 10% in size and location.
- 6.2 MEASUREMENTS AND WEIGHTS
- 6.2.1 LMP: Maximum overall width of the car: 172 mm (Excluding shell)  
Minimum weight: 730 grams.
- 6.2.2 GT17.5 Minimum Wheelbase: 184 mm  
Maximum Wheelbase: 222 mm  
Maximum overall width of the car: 172 mm (Excluding shell)  
Minimum weight is meant ready to race including lap-counting transponder during the race/heat/final.  
Minimum weight GT class: 790 grams.
- 6.2.3 Bumpers: Bumpers may be fitted but must be designed to minimise injury that could result from being hit by a car, also to reduce the risk of damage to other cars. Rigid bumpers made from non-resilient materials such as metal are not allowed. Other sheet materials should have an edge radius not less than 1.5mm. Bumpers must not protrude of the body and being fitted in the shape of the body.
- 6.3 TYRES
- 6.3.1 All tyre sizes apply at the start of the race.
- 6.3.2 Tyres Minimum width 13 mm. Maximum width 40 mm. The tyre width is measured at the widest part of the tread or sidewall.
- 6.3.3 Any tyre diameters will be allowed. The diameter must be maintained over at least the minimum width of the tyre.
- 6.3.4 Tyres must not be wet or greasy from additive at the start of a heat or final.
- 6.3.5 Technical Inspection can demand to check the tyres prior to each start.
- 7. PARTICULAR TO 1:10 ELECTRIC SALOON CARS**
- 7.1 BODIES:
- 7.1.1 Only bodies that comply to the body guideline for 1:10 electric touring car bodies as per drawings in this handbook of real touring cars that have a minimum length of 420mm in the original car are allowed. No GT or Sports car bodies allowed. All Touring car bodysHELLS to be submitted to the EFRA BodysHELL Homologation officer for approval.
- 7.1.2 The rear bumper cut-line to be maximum 35 mm from track surface, as detailed in GBS drawings. This will be measured with the chassis on a 15.0 mm block, so based on a 5 mm ground clearance the dimension used will be 45.0 mm.
- 7.2 MEASUREMENTS AND WEIGHTS  
(NOTE: Heights measured with chassis on 15.0 mm block, based on 5 mm ground clearance)  
Maximum overall width (with body): 195 mm  
Maximum overall width (without body): 190 mm  
Minimum weight: 1320 gram  
Wing: maximum wing size including endplates: 190w x 40d x 20h mm Wings to be mounted directly to the body (no spacer between shell and wing), on the moulded mounts provided at the back of the shell.  
All features (front splitter/bumpers) from the original moulding must remain on the shell.

Maximum wheel rim diameter (excl. ribs): 50 mm

The use of multiple-speed transmissions (gearboxes) and slipper clutches is not allowed.

All cars must have independent suspension operating on all four wheels (no PRO 10 cars allowed).

Only a fixed single ratio transmission is allowed and it may not include mechanical devices between the drive motor output and the gearbox input for the purposes of controlling torque (e.g. slipper clutches).

- (K) = Min 140 mm Max 155 mm
- (L) = Min 110 mm Max 125 mm
- (M) = Min 115 mm
- (N) = Max 195 mm

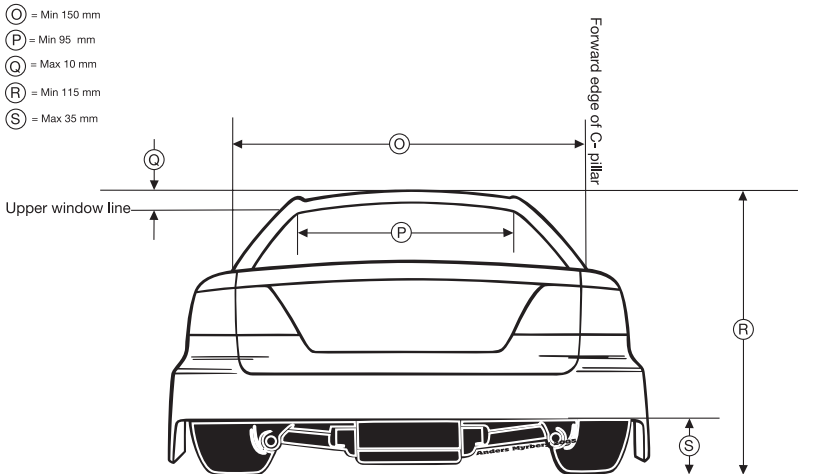
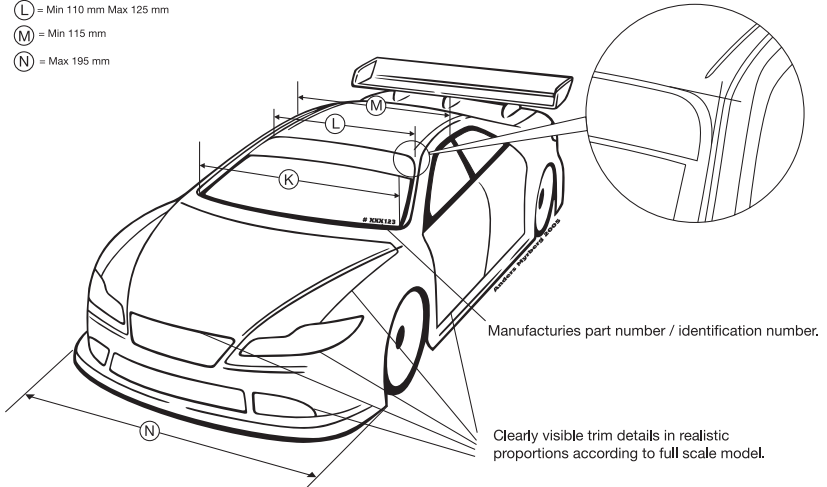

To assist competitors maintain consistent heights when using different wheels/tyres, dimensions R and S will be measured with the chassis on a 15.0 mm block. Dimensions will be based on a 5 mm ground-clearance and will therefore be :- R = 125 mm, S = 45 mm.

## GLOBAL BODY SPEC ( GBS for Electric Sedans )

- (A) = Max 10 mm
- (B) = Min 105 mm
- (C) = Max 85 mm
- (D) = Min 90 mm
- (E) = Min 65 mm
- (F) = Max 65 mm
- (G) = Max 25 mm ( Max 3 posts )
- (H) = Min 410 mm
- (I) = Min 170 mm
- (J) = Min 35 mm

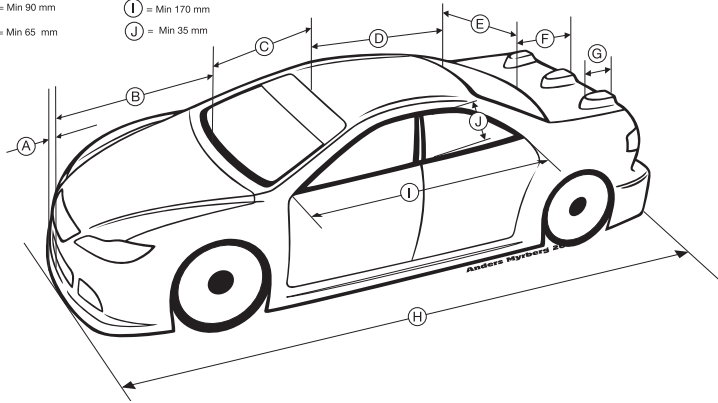

### 7.3 TYRES

7.3.1. Only moulded tyres are allowed (no sponge tyres).

Maximum tyre width            28 mm

Minimum tyre width            24 mm

7.3.2. At EC's it is only allowed to use the tyres that were agreed by the section meeting at the EFRA AGM together with the race organiser (race organiser will make their recommendation). For dry weather racing there will be a single control slick tyre with insert and will come pre-glued to the wheel (insert, tyre and wheel to be same for all drivers) and commercially available via model/hobby shops since minimum 3 months at the time the tyre choice will be presented at the AGM. For wet/damp conditions competitors will supply their own from the agreed list below. For use at the EC, the tyres must be bought from the organiser. For each competitor there must be at least 1 set of dry weather tyres available to be bought for practice at the EC.

Maximum price fixed for each EC event at the AGM. The supplier of the tyre must guarantee that the wheels tyres are of the same batch/production run. They must be the only source of supply for the event.

#### **Note for 2022**

The nominated tyre for the 2022 10th EC.

F1 front tyres: 803070 - HUDY 1/10 Formula Rubber Tire - Front.

F1 rear tyres: 803080 - HUDY 1/10 Formula Rubber Tire - Rear.

F1 Wet tyres - self supplied from an agreed list at the AGM. No list as yet.

TC Tyres: 803062 - HUDY 1/10 TC Tires A1-36 - Asphalt.

7.3.3. Tyre Allowances.

For Spec Class -2 sets of 4 dry weather tyres (rubber) are allowed for qualifying.

Tyres from qualifying may be used in the finals.

For Modified Class: 3 sets of 4 dry weather tyres are allowed for qualifying.

For Formula Class -1 set of 4 dry weather tyres (rubber) is allowed for qualifying and 1 additional set of rear dry weather tyres is allowed for the finals.

For TC FWD Class - 1 set of 4 dry weather tyres (rubber) is allowed for qualifying .

7.3.4. Tyres from qualifying may be used in the finals

- 7.3.5. For wet/damp conditions a treaded tyre may be used but only when the Race Director gives his permission. This treaded wet tyre does not form part of the limited number of sets.
- 7.3.6. Tyres/wheels may not be modified. Changing of tyres between drivers is not allowed. Drivers must have their wheels and tyres marked by Technical Inspection and this marking can be done at any time.
- 7.3.7. The Technical Inspector must mark wheels/tyres before being presented to Technical Inspection for qualifying heats and finals.
- 7.3.8. Unmarked wheels/tyres may not be used on the car during qualifying heats and finals but are allowed for practice.
- 7.3.9. Technical Inspection shall be responsible for recording the number of tyres used by each driver.
- 7.3.10. No extra sets are allowed for a re-run of a heat.
- 7.3.11. All set of tyres for qualification have to be returned by the driver by the end of each qualification day to the organizer (tyre impound). Not returning the tyres in the announced time by the organizer will be punished with the lost of the best heat. The not returned set of tyres have to be checked and released for further use by the technical inspection.
- 7.4. 1/10 TOURING CARS 13.5T SPEC. BRUSHLESS
- 7.4.1. Only 13.5T Spec Brushless motors according to App. 3A 2.2 are allowed.

## **8. PARTICULAR TO 1/10 FORMULA ONE SPEC CARS**

- 8.1. Cars specification
  - Maximum width: 190 mm
  - Front independent king pin, coil spring suspension is allowed. Suspension pick up points must be mounted inside the body. Independent front shocks are not allowed. The main chassis plate must not protrude from the body when viewed from above.
  - Minimum weight = 1050 grams including personal transponder.
- 8.3. Additive:
  - Only odourless additive is allowed (as per. rules)
- 8.4. Bodies:
  - Only Formula 1 body styles are allowed. Body must be painted in a race inspired theme. Single color themes are allowed but you must the included sticker sheet to detailed the car.
  - All cars must have a drivers figure installed in the cockpit.
- 8.5. Wings:
  - Front and rear wings must be commercially available and made of a molded ABS Style plastic. and to a design to be decided at the AGM. Front and rear wings made of Lexan material will not be allowed (this includes bolt on Lexan front wings over a smaller ABS plastic wing).
  - Wings equipped with any type of remote adjustment or DRS are not allowed
  - Maximum height of any part of the rear wing cannot exceed highest point of the body. Any bolt-on, glued-on or moulded-in elevation on the body is to be ignored for the rear wing maximum height measurement.
- 8.6. Only 21.5T Spec Brushless motors according to App. 3A 2.2 are allowed. Speed controller rules to be the same as current Spec. Touring Car rules.

## **9 PARTICULAR TO 1/10 FRONT WHEEL DRIVE CARS**

- 9.1 Only the front wheels of the car are allowed to receive the power from the motor and transmission – the rear wheels are not connected to the drivetrain in any way. An independent suspension must operate on all four wheels.

9.1.1 Cars specification

Maximum overall width:195 mm

Minimum weight = 1250 grams including personal transponder

Wing: maximum wing size including endplates:180mm wide and must be cut on the lines provided by the manufacturer. Wings to be mounted directly to the body (no spacer between shell and wing), on the moulded mounts provided at the back of the shell.

All features (front splitter/bumpers) from the original moulding must remain on the shell.

TC FWD car has to be only front wheel drive, four independently sprung wheels. The use of multiple-speed transmissions (gearbox) and slipper clutches is not allowed. No drive system may be connected to the rear wheels.

The dimensions of the car are within the 1/10th Touring car FWD dimensions.

All electronic components (including motor, ESC and battery) must be contained entirely within the bodyshell, but otherwise the position of these items within the car and the general chassis layout is free.

Bodies:

Only bodies that comply to the body guideline for 1/10th TC FWD as per drawings in this handbook of real TC FWD 5-doors that have a minimum length of 420mm in the original car are allowed. No GT or Sports car or 4-doors sedan bodies are allowed. All TC FWD bodyshells to be submitted to the EFRA Bodyshell Homologation Officer for approval.

Wings:

The rear wing must be commercially available and made of lexan only. The rear wing may have a maximum width of 180mm and must be cut on the lines indicated by the manufacturer.

No other kind of wings on the bodyshell are allowed.

Motor:

Any 21.5T brushless motor of the EFRA Homologation motorlist for Brushless Spec Motors (21.5) can be used with any Speed controller (ESC) using "0-Boost/Blinky" mode. The Maximum gear ratio is 4.5. But depending on the length/layout of the track it can be adjusted by the section chairman after consultation in the team managers meeting.

**GLOBAL BODY SPEC ( GBS for FWD Electric On-road )**

Also FWD and no TC

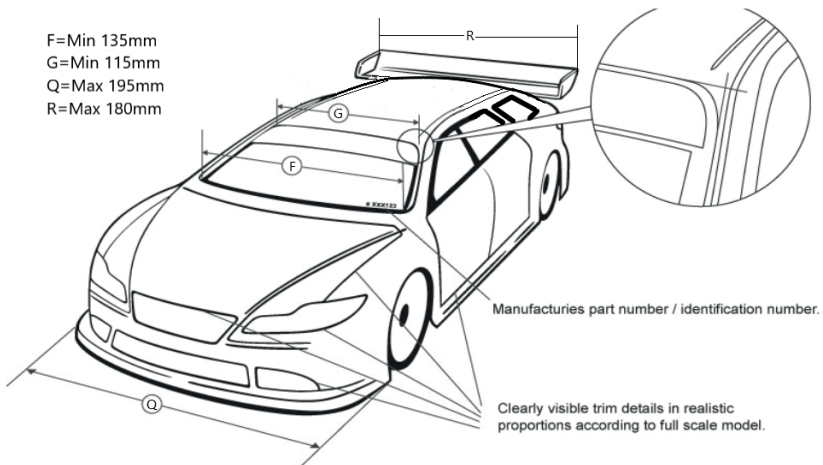

## GLOBAL BODY SPEC ( GBS FWD Electric On-road )

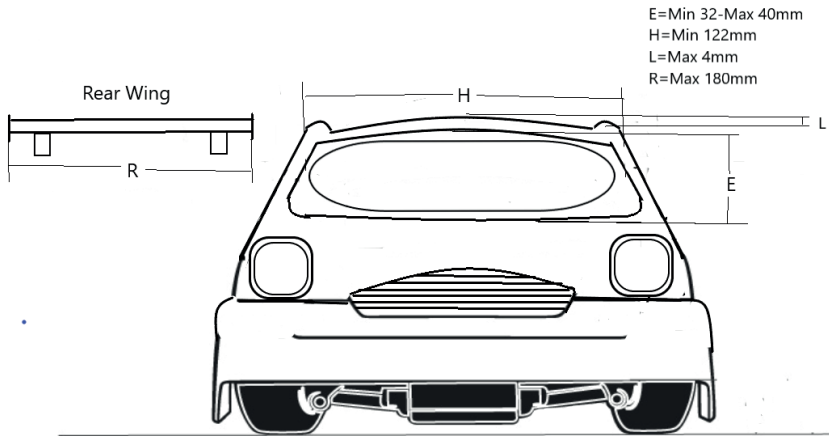

## GLOBAL BODY SPEC ( GBS for Electric FWD )

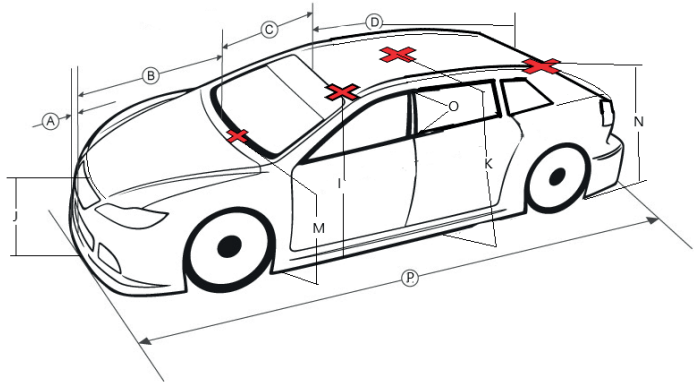

A - max 9mm	front lip (measured in the centre)	K - min 112	Height from the cut line to the highest point of the roof of the bodyshell
B - min 100 - max 110	length of the motorhood	L - max 4mm	Difference between roof rail and highest point of roof
C - min 72	Height front window	M - min 70 - max 78	Height from the cut line to the highest point at the level hood to front windshield
D - min 175 - max 200	Roof length	N - min 105mm	Height from the cut line to highest point of the rear roof at the level of the end of the roof
E - min 32 - max 50	Height Rear window	O - max 35mm	Height side window (middle)
F - min 135	Front window width below	P - min 415 - max 440	Length bodyshell
G - min 115	Front window width above	Q - max 195mm	Overall width bodyshell
H - min 122	Rear roof width (measured at the end of the roof)	R - max 180mm	Width rear wing
I - min 105	Height from the cut line to the highest point of the roof at the level of the front windscreen		
J - min 45	Height from the cut line to the beginning of the hood (make a visible line)		

A body must be a realistic representation of an original hatchback car as judged by the Homologation Officer

## **C GT12 Technical Rules**

This class is based on the principals of close, fair and low cost racing. This will make it both an ideal entry level class for the driver who wishes to try his or her hand at RC racing for the first time, but the rules for the class will also cater for the more competent driver who wishes to take their racing further. In the interests of keeping racing costs reasonable, there is strict guidance as to the use of additional upgrade parts and components. This should also ensure that the performance of each car is more dependent on driver ability and good setup than on budget. The Rules outlined below may not necessarily cover every single aspect of car construction – drivers are required to follow the spirit and intention of these rules if any ambiguity is discovered.

### **1 Construction Rules**

- 1.1 The essence of the sport of Radio-controlled car racing is competition between realistic models of racing automobiles. All cars must comply with dimensional requirements stated in these Rules.  
All cars will use replica GT shells from the list of eligible shells given in Appendix 1
- 1.2 Minimum weight is 950 grams, ready to race including lap-counting transponder at all times during the race/heat/final.
- 1.3 Wheel rim diameter maximum is 40mm, and 26mm Width. Only commercially available wheels may be used. No modifications or changes to the original manufacturer's design and dimensions are allowed.
- 1.4 The tyres must be black except for side wall detail.
- 1.5 Tyre additive for each meeting is to be agreed by the organiser and the EFRA Electric Chairman.
- 1.6 Tyres must have a minimum width of 20mm and a maximum width of 26mm.
- 1.7 Wheel nuts and/or axles must not protrude more than 2.0mm beyond the outer edge of the wheels. No more than 1.5mm of wheel outer side may be exposed (not covered with rubber) on the outer edge of wheels.
- 1.8 Bumpers may be fitted but must be designed to minimise injury that could result from being hit by a car, also to reduce the risk of damage to other cars. Rigid bumpers made from non-resilient materials such as metal are not allowed. Other sheet materials should have an edge radius not less than 1.5mm.
- 1.9 Only one wing is allowed on the car, maximum dimensions to be, width 165mm, chord 50mm, unless the original car had more than one wing. The second wing must be to scale within 10% in size and location.
- 1.10 Overall maximum width of the rolling chassis to be 165mm including wheel nuts and axles, not including bodyshell. Wheelbase is to be 196mm minimum to 208mm maximum.
- 1.11 All cars must have clear windscreens, unless the actual car did not have clear windscreens.
- 1.12 Side and/or rear windows, if any, must be clear.
- 1.13 All cars to have clearly visible identifying numbers to the Race Directors satisfaction.
- 1.14 Numbers must be at least 25mm high with minimum stroke of 4mm. They must be black numerals on a white background.
- 1.15 No portion of the chassis or any equipment may extend beyond the body, except aerial masts, rear diffuser (if fitted) and up to four posts for the purpose of mounting the body shell.
- 1.16 Flexible masts/tubes only may be used.
- 1.17 Openings in the body other than ones appropriate to full size cars shall be kept to a minimum.



- 1.18 Wheel cut-outs may not be more than 10mm larger than the tyre radius. Exception- scale size and/or shape wheel well cut-outs. Wheel wells must be cut out if the original cars are cut out.
- 1.19 When initially entered in a meeting the body shell must be neatly finished and complete 1.20 Body and chassis must be securely joined at all times while the car is on the track.
- 1.21 Body shells must be listed in Appendix 1 to these Rules to be eligible for use. Body shells when painted must have a minimum of headlights, front grill and rear lights picked out in a realistic colour, size and shape that clearly separate them from the other body colours. Additional grills and intakes picked out in the same way are preferred. Windows will be clear, may not be cut out, and will be shaped as per the original car. Bodies must not be cut above the lower cut lines marked on the body shell. If there is a diffuser cut line, the bodyshell may be cut to this line.
- 1.22 Only one drive motor is allowed per car.
- 1.23 The minimum ground clearance of the car, not including the spur gear, is 3mm; minimum 1mm under the spur gear; this will be checked during scrutineering for each qualifying heat and final race.
- 1.24 Only Personal Transponders will be used to record laps.

### **3 Definition of Brushless Motor**

- 3.1 13.5 Spec. Brushless - Any motor listed in any of the Homologation List for Brushless Spec Motors 13.5 Spec
- 3.2 17.5 Spec. Brushless - Any motor listed in any of the Homologation List for Brushless Spec Motors 17.5 Spec

### **4 Definition of a Zero-timing Speed Controller**

- 4.1 Speed controllers may not be equipped with any form of automatic or programmable timing advance. If this feature is available on the particular speed controller it must be disabled and placed in an approved mode - i.e. the "ROAR blinking LEDs mode." Only Speed controllers from the Approved Blinky ESC's list may be used.
- 4.2 Reverse function must not be used in GT12-class.

### **5 Batteries Allowed**

- 5.1 Only Batteries listed on the current EFRA '1S Stick Lithium Battery Homologation List' can be used. See Appx. 4
- 5.2 GT12 Cars will be driven by lithium based (LiPo/LiFe) batteries with a nominal voltage of no more than 3.8v.

### **6 Chassis and Components**

- 6.1 The chassis component will consist of one continuous sheet of material that extends from a minimum 10mm ahead of the front axle line and runs continuously along the car to end 25mm minimum behind the rear axle line. The chassis may not include any features designed to allow the front and rear axle to rotate along the central axis of the car relative to each other. (Intent – that the chassis supports all the suspension components and is sufficiently rigid not to be used as a working part of the suspension system/s).
- 6.1.1 Chassis shape and hole pattern to be homologated, Manufacturers may submit a maximum of 3 designs per 12 month period. Legal chassis listed in appendix 2.
- No modifications to chassis
  - Design may be offered in a "alloy" or "composite" version
  - Edges may be smoothed / sanded / sealed
  - Chassis must be commercially available
- 6.1.2 Metals used in the production rolling chassis and any aftermarket parts may

only be brass, steel or aluminum with the exception of the GT12 Super-Cup class where, solely for the use as turnbuckles, titanium will be allowed. Brass, lead, and steel may be used as weights.

6.1.3 Cutouts: Wheel cut-outs may not be more than 15 mm larger than tyre radius (Exception - scale size and/or shape wheel cut-outs). Wheel wells must be cut out if those on the original car were cut out.

6.1.4 Wing and Spoiler LMP class:

Only one wing is allowed on the car unless the actual car had a second wing. The second wing must be scale within 10% in size and location. The wing may be not closer than 6.5 mm to any part of the body other than the tail fins or side dams.

Wing: Maximum width: 172 mm, the wing profile must fit in a rectangle of 52mm (height) x 26 mm.

Spoilers: Max. Spoiler height: 25 mm, max length 35 mm.

These dimensions include the moulded in portions of the body, the use of a gurney flap to extend the wing length is acceptable.

6.1.5 Wing and Spoiler GT class:

Only one wing is allowed on the car, maximum dimensions to be, width 165 mm, chord 50mm, unless the original car had more than one wing. The second wing must be to scale within 10% in size and location.

6.2 All suspension systems must operate independently of the chassis component.

6.2.1 Separate dampers are only allowed on the rear suspension. Dampers requiring seals to prevent the egress of any type of damping medium are not allowed. (Intent – that dampers are non-sealed ‘straw’ or ‘tube’ style. Dampers with any type of damping medium contained in a sealed reservoir are not permitted).

6.3 Front suspension may be independent provided that the suspension design does not have any pivot, rod or other mechanism that alters the wheel camber in roll relative to the chassis during its full travel. (Intent – that suspension systems from Touring Cars, GT10 cars, 12th cars and F1 cars featuring pivoting suspension arms are not used).

6.4 The rear axle must not have any articulated element and may be fitted with a differential

6.5 Only a single fixed speed transmission is allowed.

6.6 Gears in the single fixed speed transmission must be 32DP or 48DP only.

6.7 Rolling element (ball) bearings are allowed on the front and rear axles.

6.8 Cars may only have two driven wheels with the drive to the rear axle.

### **End of Construction rules**

## **GT Body Shells**

Only GT body shells are allowed. At the time of submission for homologation, the full-sized car upon which the body shell is based must be currently FIA homologated (for GT Competition) and have been raced within previous 3 years. All shells must be a reasonable representation of the full-sized car. The following link contains info on the current FIA GT homologated lists. Only cars listed in the GT3 class are eligible. Use “list of Homologated Vehicles classified by number”. <https://www.fia.com/homologations> As part of the homologation process, the manufacturer’s part number must be clearly marked in the lower corner of the windscreen area. Body shells when painted must have a minimum of headlights, front grill and rear lights picked out in a realistic colour, size and shape. The Body shells must not be cut above the lower cut lines marked on the body shell. If there is a diffuser cut line, the bodyshell may be cut to this line.

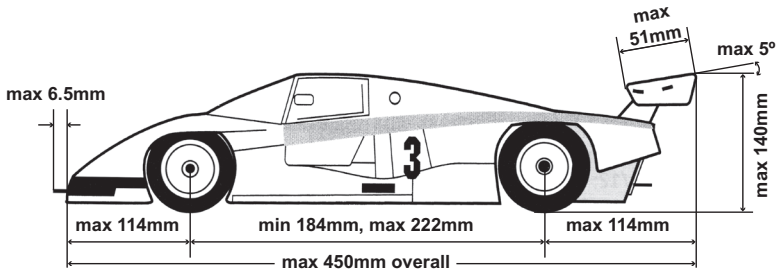

The following is the list of approved bodies for the GT class:

#### **Kamtec**

- Kamtec Lotus GT1 (Kamtec part no. GT01)
- Kamtec Ascari GT3 (Kamtec part no. GT02)
- Kamtec Aston Martin (Kamtec part no. GT03)
- Kamtec Type F (Kamtec part no. GT04)
- Kamtec Porsche GT3 (Kamtec part no. GT05)

#### **Mardave**

- Mardave Lotus GT1 (Mardave part no. V140)
- Mardave Ascari GT3 (Mardave part no. V151)
- Mardave Aston Martin (Mardave part no. V160)
- Mardave GT2 (Mardave part no. V131)
- Mardave Porsche (Mardave part no. V113)
- Mardave Ginetta (Mardave part no. V161)

#### **Penguin Custom Bodyshells**

- Lambo GT12 (part number PEN01)

#### **Protoform**

- Protoform PF-M12 (Protoform part no. #1613-30)

#### **Screwz4RC**

- Audi R8 (part number G903)

#### **Zen-Racing**

- Zen-Racing GTM (part number PBGT02)
- Zen-Racing GTF (part number PBGT03)

#### **Montech**

- Montech MLGT3 (part number MT018001)

The following link contains info on the current FIA GT homologated lists. Only cars listed in the GT3 class are eligible. <https://www.fia.com/homologations> Use "list of Homologated Vehicles classified by number".

## **Chassis**

The following is the list of approved Chassis's for the GT12 class.

Chassis shape and hole pattern to be homologated, Manufacturers may submit a maximum of 3 designs per 12 month period.

- No modifications to chassis
- Design may be offered in a "alloy" or "composite" version
- Edges may be smoothed / sanded / sealed
- Chassis must be commercially available

#### **Schumacher**

- U3981 SupaStox Chassis 6 Cell/2s Saddle

U3957 SupaStox Chassis 4 Cell/1s/Shorty  
U4649 SS GT - S1 Chassis  
U4623 SS GT - C/F Chassis  
U4816 Atom - Alloy Chassis  
U7276 Atom CC - C/F Chassis

**Zen-Racing**

ZENC101 RSGT12 Main Chassis  
ZENC106 RSGT12 Twill Carbon  
ZENA100 RXGT12 Aluminium Chassis  
ZENC150 RXGT12 Carbon Chassis

**Mardave**

MARCE-01 Mardave CE  
MARCEC-01 Mardave CEC  
MARAC-12 Mardave AC12  
MARA-001 Assassin  
MARGT-001 Assassin GT  
MARVEN-001 Venom  
MARVGT-001 Venom GT - Carbon Chassis  
MARVCC-001 Venom CC - Alloy Chassis

**ORE**

R318 ORE TwelveGT Carbon  
R653 ORE B2B Carbon  
R722 ORE B2B-W17 Alloy

**D PARTICULARS for 1/10 OFF ROAD**

**1. GENERALITIES:**

- 1.1 Cars entered for off-road competitions should be reasonable representations of the style of full size cars generally accepted as being suitable for rally-cross, rallying or desert racing.
- 1.2 There are two classes of cars: 2WD and 4WD. Both must be run and drivers are allowed to enter both classes. Any car competing in the 4WD Class must have effective drive to the front and rear wheels (race breakages excepting). Any car which is designated as 4WD must be able to complete a lap of the track with either the front or rear drive-shafts removed with all settings of the remaining drive-train as it will be raced, in a reasonable time frame.
- 1.3 All open gears must be enclosed or protected so as to prevent injuries.
- 1.4 Any modification to the car is allowed.
- 1.5 A differential may include a mechanism for apportioning torque over the axle/s (e.g. limited slip differential). This mechanism must only be capable of adjustment manually whilst the car is stationary

**2 MEASUREMENTS AND WEIGHTS:**

Maximum overall length: 460 mm  
Maximum overall width: 250 mm (At any point of suspension travel)  
Maximum overall height: 200 mm (to be measured with the suspension fully compressed)  
Minimum weight 2WD cars: 1.474 gram  
Minimum weight 4WD cars: 1.588 gram  
A maximum of two (2) wings can be used, one at the front and one at the rear of the car:

Maximum size of Front Wing: 127.0 mm wide with chord 63.5 mm. max.

Maximum size of Rear Wing; 177.8 mm wide with chord 76.2 mm max.

Maximum size of Wing side-dam: Height 50 mm, length 80 mm

Maximum overall diameter of wheel & tyre: 90 mm

Wheel sizes:

Min bead mounting diameter: 41.28 mm

Max bead mounting diameter: 55.88 mm

Bead mounting dimensions are measured at the point where the internal tyre bead meets the wheel.

Max wheel diameter: 61.47 mm

Max wheel width: 38.10 mm

Wheel width is measured at the circumference of the wheel where the tyre is retained, the centre of the wheel maybe outside this dimension.

'Venting' holes in the internal rim of the wheel are allowed – maximum of two (2) holes, of maximum 6.0 mm diameter.

Measuring equipment for width, length and height should be constructed preferably from metal or alternatively high quality board. The materials will be of suitable thickness to eliminate any distortion.

Design of the equipment to allow all points of the car to be measured.

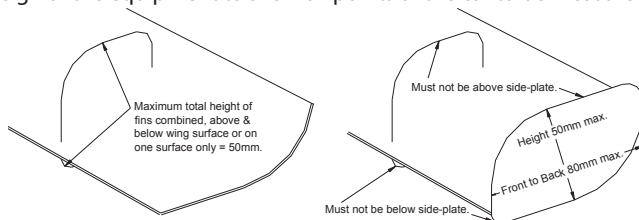
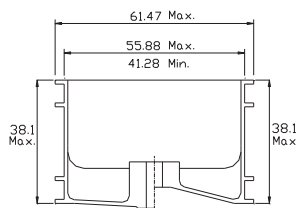

Vertical 'fins' included or attached within the wing area, must be no higher (or lower) than any side-plates. If no side-plates are used, any vertical 'fins' within the wing area must not exceed 50mm maximum overall (top to bottom). Front or Rear bi-level wings are not permitted. See diagram.

### 3 TYRES

3.1 Grand Prix: Any combination of commercially available 1/10th scale wheels and tyres may be used.

3.2 European Championships: The organizer will propose 1 type of tyre for each of the driven axles for 2WD and 4WD (2WD and 4WD do not have to be the same type of tyre). The manufacturer and full description of the tyres chosen must be given, but there remains free choice of compound. The proposed tyre choice will be ratified at the EFRA section AGM prior to the EC and provided always that the chosen tyres are commercially available throughout the EFRA Nations. The manufacturer(s) of the chosen tyres will be notified which specific tyre has been chosen as soon as the decision is finalised.

Valid from 2016:

European Championships: The organizer will propose 1 type of tyre for each of the driven axles for 2WD and 4WD. The manufacturer and full description of the tyres chosen must be given, compound and inserts will be controlled, and will only available in a restricted area and should be sold to the driver by the organiser

and if possible at a lower price. The proposed tyre choice will be ratified at the EFRA section AGM prior to the EC and provided always that the chosen tyres are commercially available throughout the EFRA Nations. The manufacturer(s) of the chosen tyres will be notified which specific tyre has been chosen as soon as the decision is finalised. Rule applies from 2016 onwards

- 3.3 No metal or hard plastic may be used for spikes
- 3.4 Modifications to tyre tread patterns and 'location beads' are allowed by trimming or removal, but the addition of any material is prohibited excepting the glue used to retain the tyre to the wheel. 'Cut and Shut' is permitted at Grand Prix only and even so if the parts of one or more different tyres are glued together, provided always that the constituent parts are all recognisable as coming from commercially available 1/10th scale tyres.
- 3.5 No sponge or foam tyres are allowed except for foam inserts completely enclosed within the sidewalls.
- 3.6 Only cleaning of the tyre bead where the tyre is glued to the wheel is allowed. No tyre additives other than water are allowed on any of the other surfaces of the tyre, inside or outside of any tyre. No additives are allowed to be applied to any tyre insert. Excess of glue deemed to alter the performance of the tyre is not allowed. The use of any additives that is deemed by officials for the purpose of improving the tyre performance will result in disqualification from the event.
- 3.7 The use of any 'tyre warming device' is not allowed at any EFRA sanctioned events in 1/10 Off-Road (no tyre warming allowed). This includes Free Practice, Controlled Practice, Qualifying and Finals.

**4 RAIN PROCEDURE for QUALIFYING**

- 4.1 The Race Director and the Referees are jointly responsible for the decision to stop racing in the event of adverse weather conditions. If in doubt or they do not agree they can consult the EFRA rep. or his deputy ( if at the meeting ) for advice.
- 4.2 When Racing is suspended as per the rule above, then racing will recommence, when weather permits, with the heat that was next to be run prior to the interruption. If the serie of heats / round cannot be completed the same day that particular round will be cancelled and next day will start with a new (complete) round.
- 4.3 Every effort should be made by the Race Director / organizing club to make necessary repairs to the racing surface prior to recommencement of racing to give the racers in the next heats an more or less equal chance to qualify compared to the heats raced before the meeting was stopped. If that is not possible racing should be re-started with the next qualifying round.

**5 BODY SHELL HOLES/VENTS:**

The front and rear ends of the shell must retain some of the original profile of the two ends of the shell. Front and rear facing areas within the body shell surface which are 'marked' with the intention of removal to form "air scoops/vents" are allowed to be removed, within a maximum dimension of 10mm in any direction regardless of the manufacturers marking. If no "marked" air scoops/vents are designed in the original mould to assist airflow to the motor or ESC, then material may be removed to a maximum of 10 mm. in any direction within a maximum square area of developed size 30 mm x 30 mm, in two places only. Windows are not allowed to be removed or include holes, other than for the purpose of the antenna.

